

SURE-LOCK ROOF CURB SUBMITTAL #1007799

GRANDAIRE T1CURB20AN1-14

PART NUMBER

CAMBRIDGEPORT
1007799

DWG# 1007799 SUBMITTAL
REV
Drawn By: CJT
Drawn Date: 01/05/07

ESTIMATED WEIGHT: 105

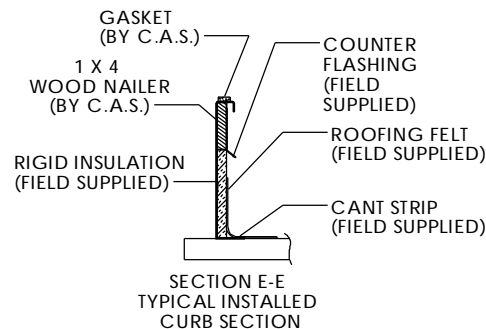
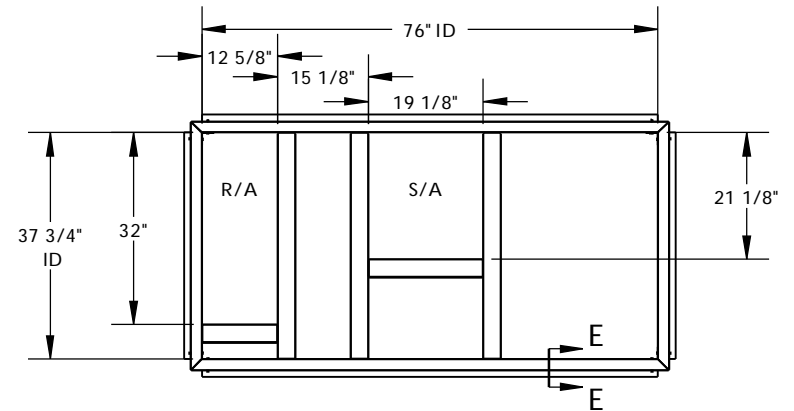
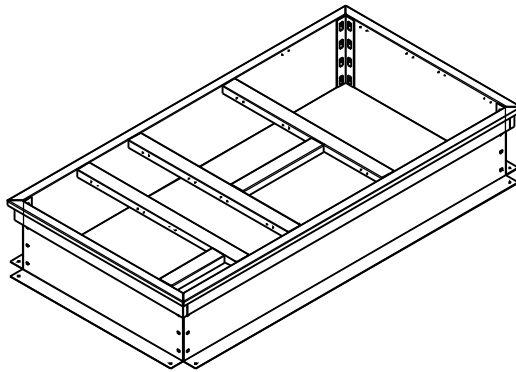

FEATURES:

MITERED TOP CORNERS

ROOF CURB BODY IS FABRICATED OF HEAVY GAUGE GALVANIZED STEEL.

FULL PERIMETER WOOD NAILER.

PRE-PUNCHED ASSEMBLY HOLES AND HARDWARE INCLUDED FOR DUCT SUPPORT INSTALLATION,

ROOF CURB IS SHIPPED KNOCKED DOWN.

Cambridgeport
AIR SYSTEMS, INC.

SALISBURY, MA 01952

PHONE 1-800-648-2872 FAX 1978-462-9189