

DATE: _____
 COMPANY: _____
 JOB NAME: _____
 SUBMITTED BY: _____
 NOTES: _____

**SURE-LOCK ROOF CURB
 SUBMITTAL EMS #1000006**

YORK 1RCO-436

**CURB NUMBER
 1000006**

Drawn By: RTO
 Drawn Date: 02/06/07

REV:

ESTIMATED WEIGHT: 201 LBS.

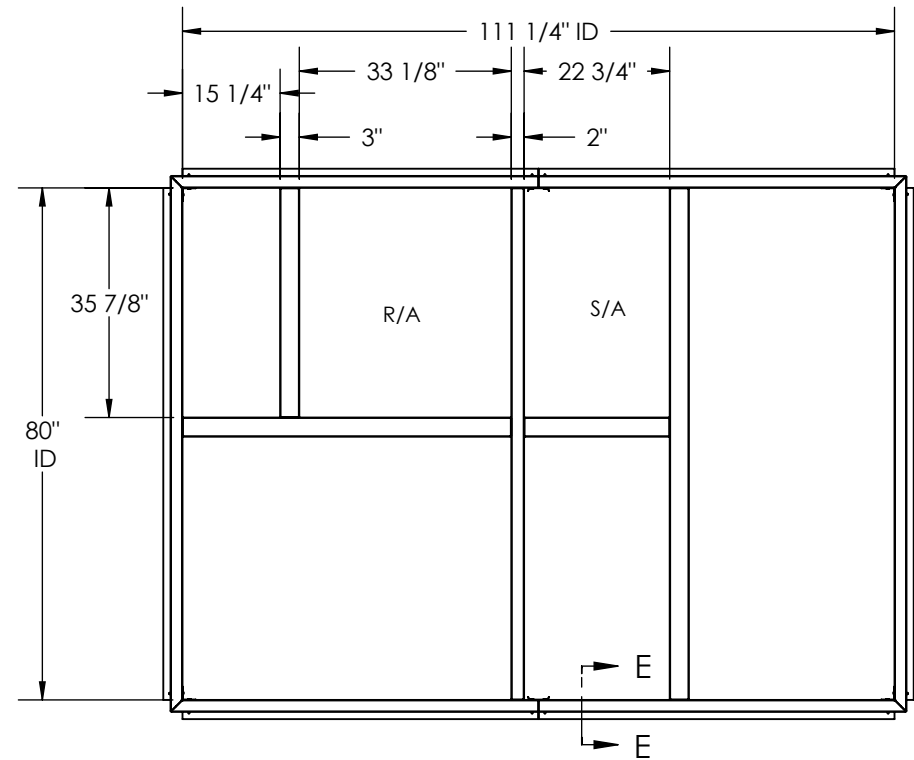
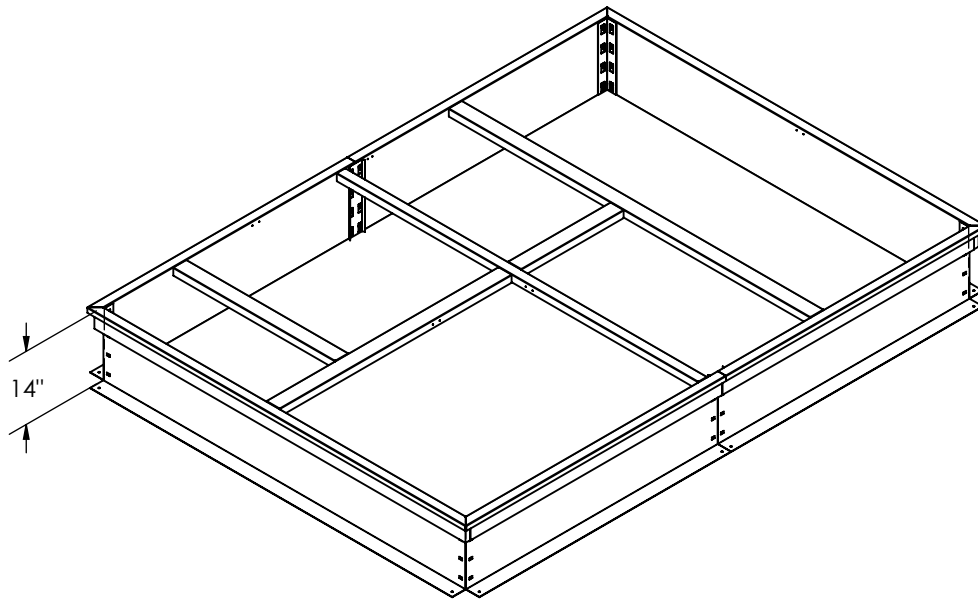

FEATURES:

- MITERED TOP CORNERS
- ROOF CURB BODY IS FABRICATED OF HEAVY GAUGE GALVANIZED STEEL.
- FULL PERIMETER WOOD NAILER.
- PRE-PUNCHED ASSEMBLY HOLES AND HARDWARE INCLUDED FOR DUCT SUPPORT INSTALLATION.
- ROOF CURB IS SHIPPED KNOCKED DOWN.
- ROOF CURB IS SEISMIC RATED AND CAN BE CERTIFIED UPON REQUEST

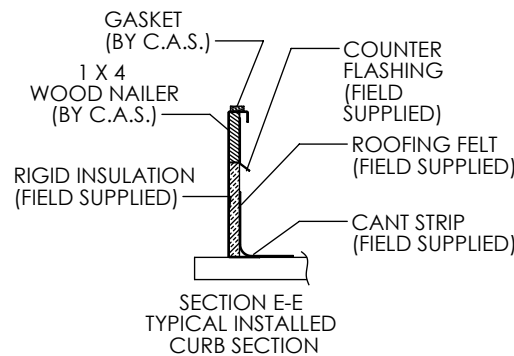

TM

Cambridgeport
AIR SYSTEMS, INC.
 SALISBURY, MA 01952
 PHONE 1-800-648-2872 FAX 1978-462-9189