

ROOF CURB ASSEMBLY INSTRUCTIONS EMS#1001831

YORK 471

CURB ASSEMBLY NUMBER

1001831

Drawn By: CJT
Drawn Date: 05/31/07

REV:

ESTIMATED WEIGHT: 194 LBS.

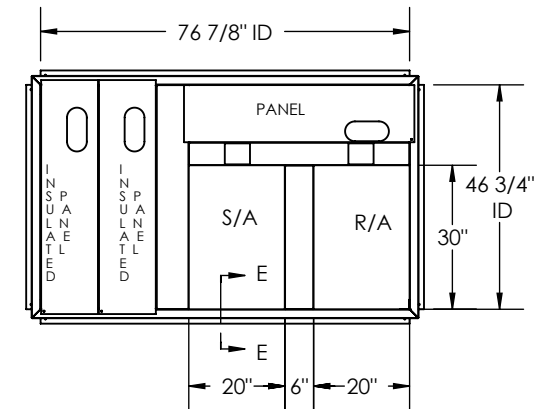
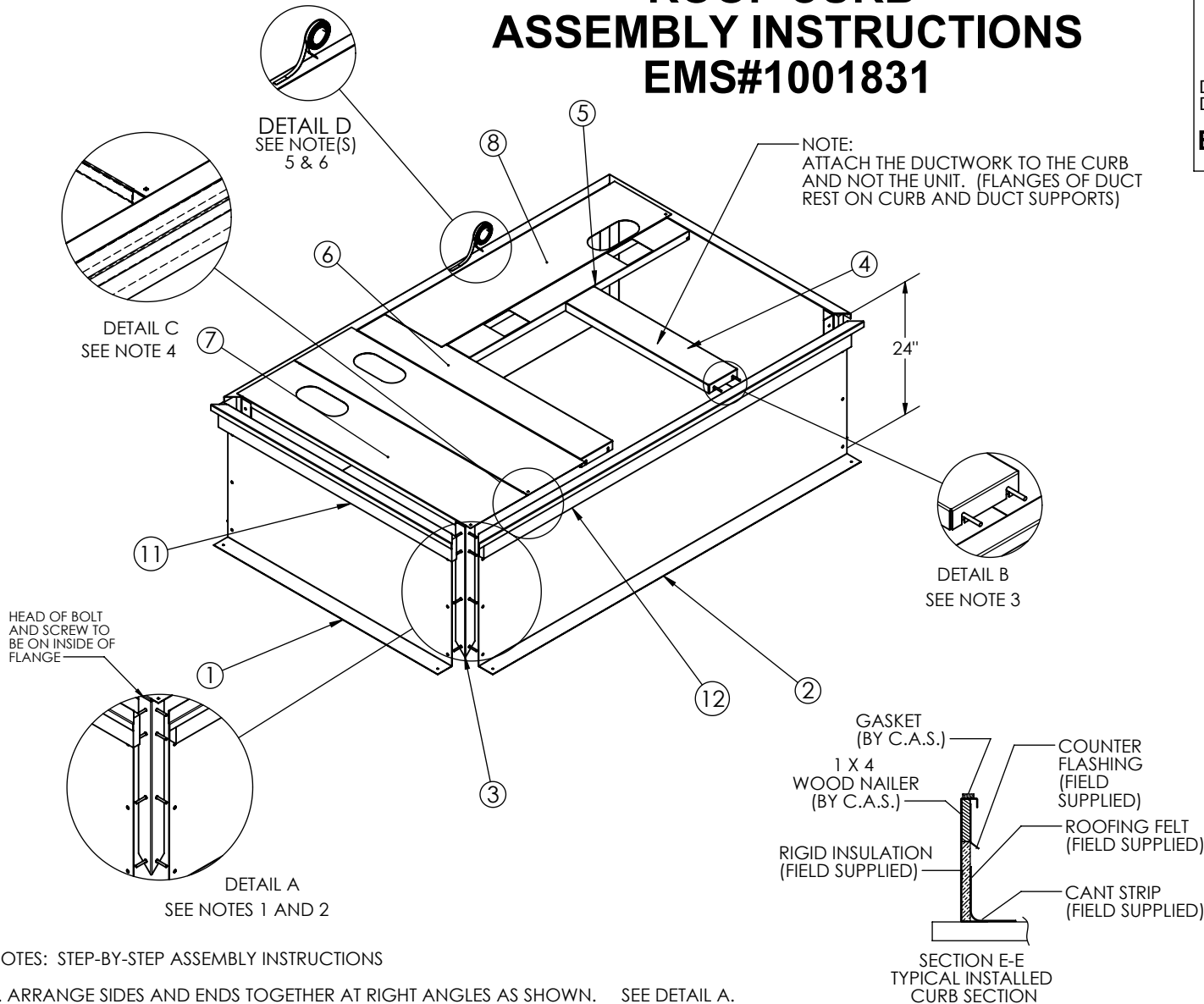

13	Bag, Hardware, #1 CP	1
12	1X4 X 76 3/4"	2
11	1X4 X 48 3/4"	2
10	GASKET 1-1/4X 3/4 X 10' LOW DENSITY	1
9	GASKET 1-1/4X 1/4 X 25'	1
8	PANEL INSULTD	1
7	PANEL INSULTD	2
6	SUPPORT, DUCT	1
5	SUPPORT, DUCT	1
4	SUPPORT, DUCT	1
3	CORNER CLIP 1	4
2	SIDE-2	2
1	SIDE-1	2
ITEM NO.	DESCRIPTION	QTY.

TM

Cambridgeport
AIR SYSTEMS, INC.

SALISBURY, MA 01952

PHONE 1-800-648-2872 FAX 1978-462-9189

NOTES: STEP-BY-STEP ASSEMBLY INSTRUCTIONS

- ARRANGE SIDES AND ENDS TOGETHER AT RIGHT ANGLES AS SHOWN. SEE DETAIL A.
- BOLT SIDES AND ENDS TOGETHER AS SHOWN USING THE 4 CORNER BRACKETS, BOLTS, AND THE TEK SCREWS PROVIDED. SEE. DETAIL A.
- PUT 10-16 X 3/4" TEK SCREWS IN PROVIDED PILOT HOLES IN SIDES AND ENDS AS NECESSARY. INSERT SLOTTED ENDS OF DUCT SUPPORTS OVER SCREWS AND TIGHTEN IF NECESSARY. REPEAT AT ALL DUCT SUPPORT LOCATIONS. SEE DETAIL B.
- WHEN INSULATED PANELS ARE INCLUDED PLACE THE INSULATED PANELS TOGETHER WITH FORMED FLANGES FACING DOWN ALLOWING FLANGED PORTION OF PANELS TO REST ON SIDE RAILS. (GASKET WILL HOLD PANELS IN PLACE.) SEE DETAIL C.
- REMOVE PAPER BACKING FROM THE PROVIDED GASKETING AND APPLY TO TOP PERIMETER OF ROOF CURB AND DUCT SUPPORTS. (SEE ILLUSTRATION ABOVE). SET CURB IN PLACE OVER ROOF OPENING. LEVEL CURB AND SECURE TO ROOF. SEE DETAIL D.
- IMPORTANT: THE GASKETING OF THE UNIT TO THE ROOF CURB IS CRITICAL FOR WATER TIGHTNESS. INSTALL GASKET SUPPLIED WITH ROOF CURB AS SHOWN IN DETAIL D, & NOTE 5. IMPROPERLY APPLIED GASKET CAN RESULT IN AIR LEAKS AND POOR UNIT PERFORMANCE.**