

Cambridgeport

SUBMITTAL

SUBMITTED TO _____
COMPANY _____
JOB NAME _____
EQUIPMENT _____
SIGNATURE _____
DATE _____

BURGLAR BAR INSERTS FOR TRANE ROOFTOP UNITS

Y*C, T*C 072A, 090A, 092A

Y*C, T*C 102A, 120A

YHC 048E, 060E, 072E

WSC 072A, 102A, 120A

PART #

1005570

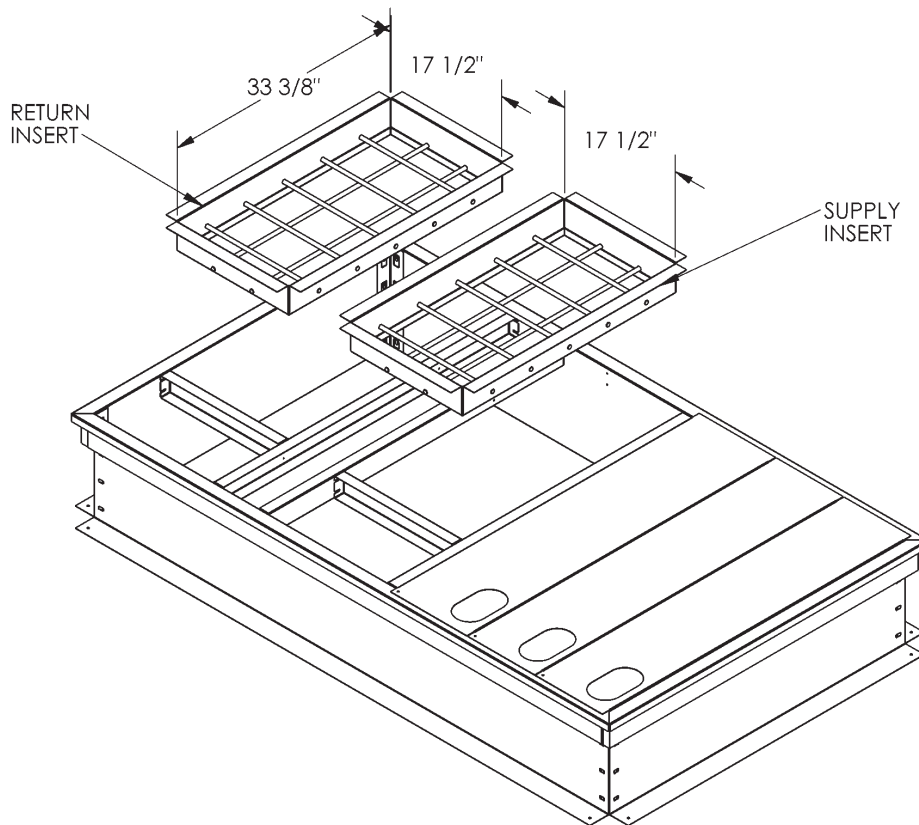

FEATURES

BURGLAR BAR INSERTS ARE FABRICATED OF 18 GA G90 GALVANIZED STEEL AND 1/2" STEEL ROD

ONE-PIECE WELDED CONSTRUCTION

ALL WELDS SPRAYED WITH GALVANIZED COMPOUND

DISTANCE BETWEEN STEEL RODS ARE NO MORE THAN 6 INCHES

OPTIONAL FEATURE;

5/8" STEEL ROD

OPENINGS GREATER THAN OR LESS THAN 6 INCHES