

DATE: _____
 COMPANY: _____
 JOB NAME: _____
 SUBMITTED BY: _____
 NOTES: _____

SURE-LOCK ROOF CURB SUBMITTAL #1006102 SEISMIC RATED

CARRIER 34A PG16

SURE-LOCK CURB NUMBER

1006102

REV:

Drawn By: CJT
 Drawn Date: 09/14/07

ESTIMATED WEIGHT: 240 LBS.

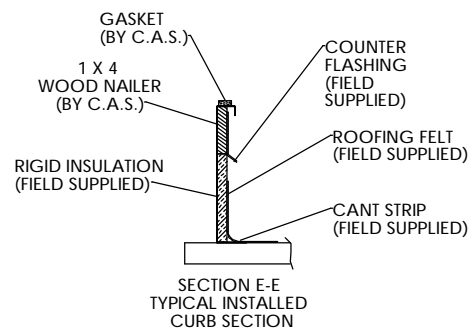
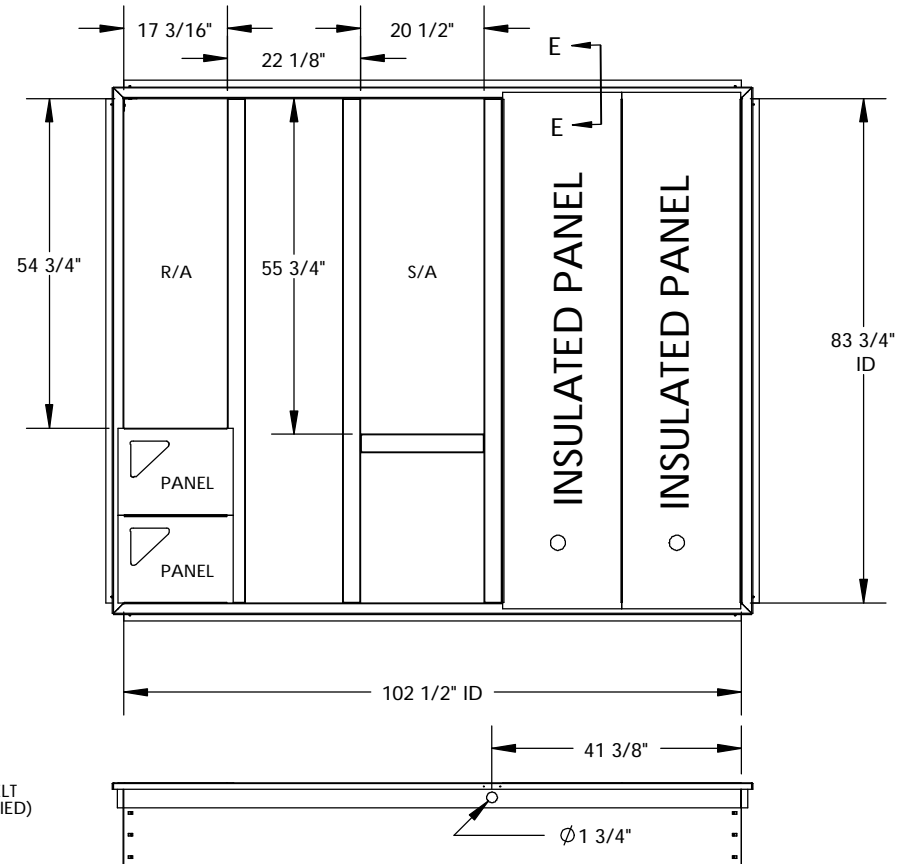
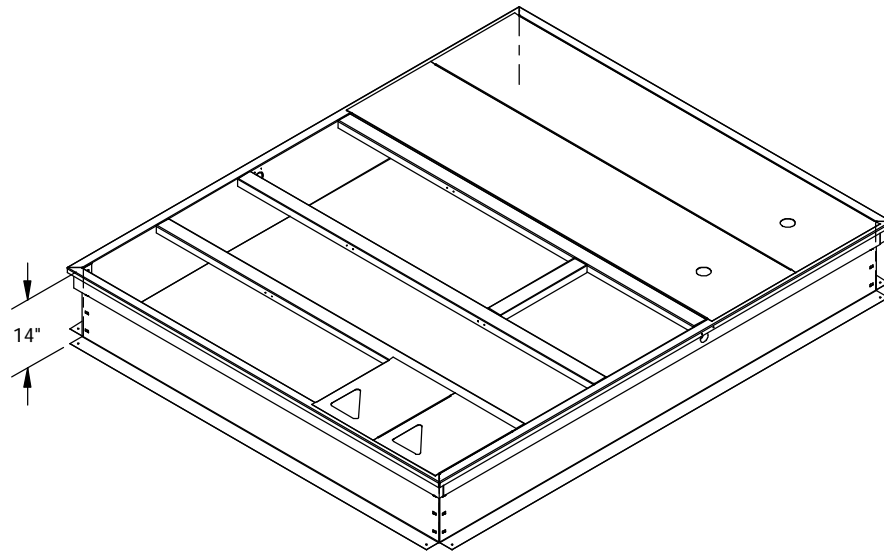

FEATURES:

MITERED TOP CORNERS

ROOF CURB BODY IS FABRICATED OF HEAVY GAUGE GALVANIZED STEEL.

FULL PERIMETER WOOD NAILER.

PRE-PUNCHED ASSEMBLY HOLES AND HARDWARE INCLUDED FOR DUCT SUPPORT INSTALLATION.

ROOF CURB IS SHIPPED KNOCKED DOWN.

ROOF CURB IS LABELED WITH RTU# IF APPLICABLE

CambridgeportTM
 AIR SYSTEMS, INC.
 SALISBURY, MA 01952
 PHONE 1-800-648-2872 FAX 1978-462-9189