

DATE: _____
 COMPANY: _____
 JOB NAME: _____
 SUBMITTED BY: _____
 NOTES: _____

ROOF CURB SUBMITTAL #1006610

CARRIER 48/50PG 08-14

CURB ASSEMBLY NUMBER

1006610

REV:

Drawn By: RTO
 Drawn Date: 12/19/06

ESTIMATED WEIGHT: 189 LBS.

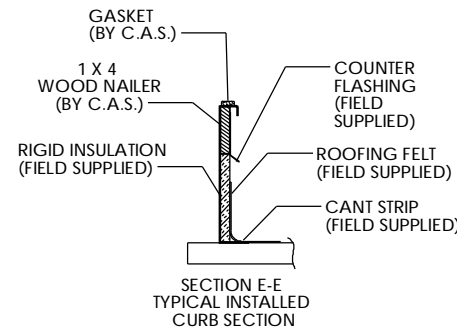
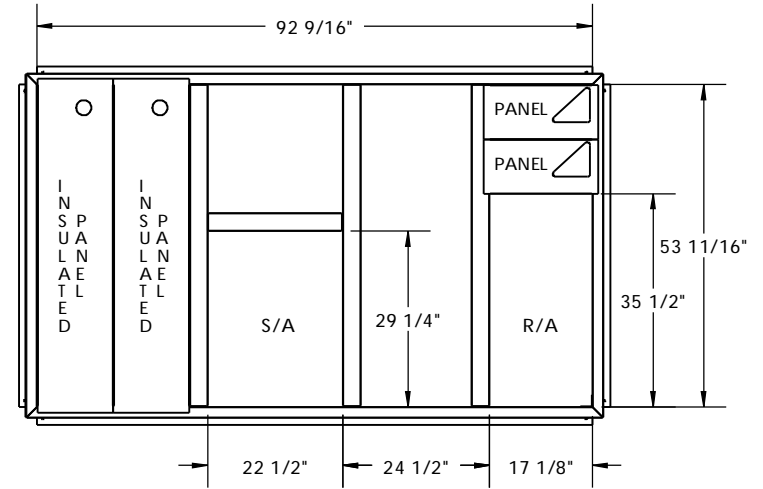
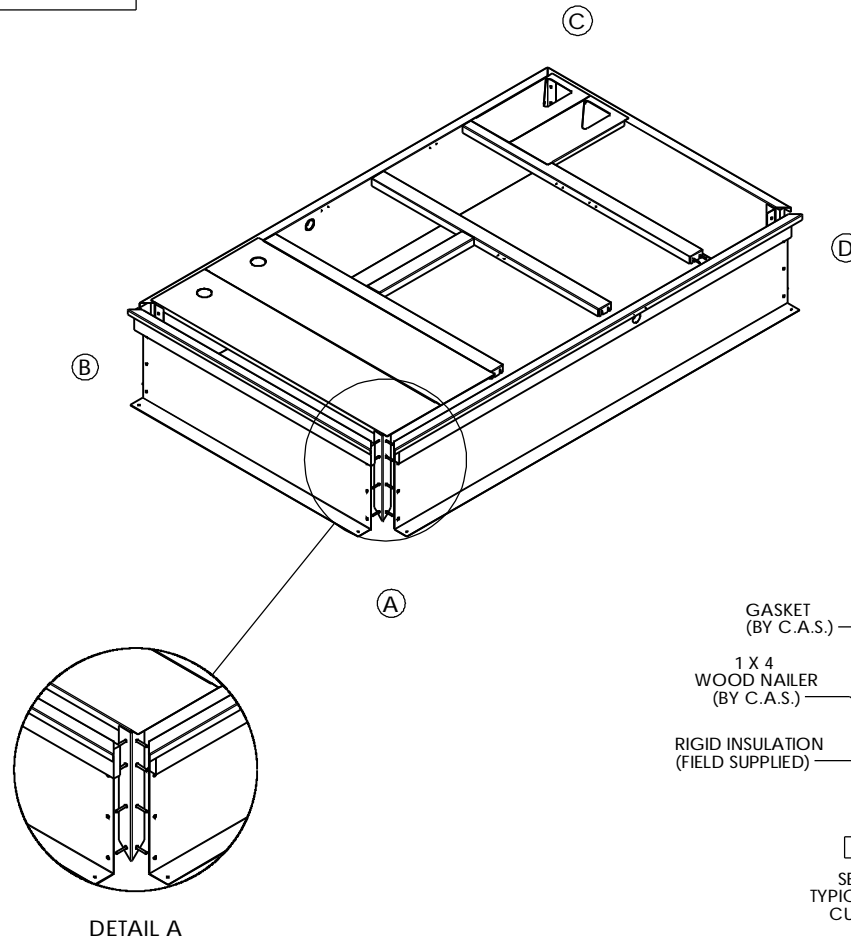

FEATURES:

MITERED TOP CORNERS

ROOF CURB BODY IS FABRICATED OF HEAVY GAUGE GALVANIZED STEEL.

FULL PERIMETER WOOD NAILER.

PRE-PUNCHED ASSEMBLY HOLES AND HARDWARE INCLUDED FOR DUCT SUPPORT INSTALLATION,
 ROOF CURB IS SHIPPED KNOCKED DOWN.

ROOF CURB IS LABELED WITH RTU# IF APPLICABLE

RTU#	HEIGHT OF CORNER A	HEIGHT OF CORNER B	HEIGHT OF CORNER C	HEIGHT OF CORNER D
	18"	18"	18"	18"

TM

Cambridgeport
 AIR SYSTEMS, INC.
 SALISBURY, MA 01952
 PHONE 1-800-648-2872 FAX 1978-462-9189