

# Cambridgeport

## SUBMITTAL

SUBMITTED TO \_\_\_\_\_  
 COMPANY \_\_\_\_\_  
 JOB NAME \_\_\_\_\_  
 EQUIPMENT \_\_\_\_\_  
 SIGNATURE \_\_\_\_\_  
 DATE \_\_\_\_\_

## ISOLATION RAILS FOR YORK ROOFTOP UNITS

**BQ, DJ, DH, DM, DY, XP, ZJ, ZR, 036-060**  
**BCH, DEE, DEG, DHE, DHG 036-060**  
**DEG, DCE, BP, DF, DM, DR, ZF 036-072**  
 \*\*Note: Units with Bottom condensate Drain  
 require 1RCO442. Call for Pricing\*\*

Description	Part #
1" Deflection KD	1009770
2" Deflection KD	1009771
1" Deflection Assem	1009772
2" Deflection Assem	1009773

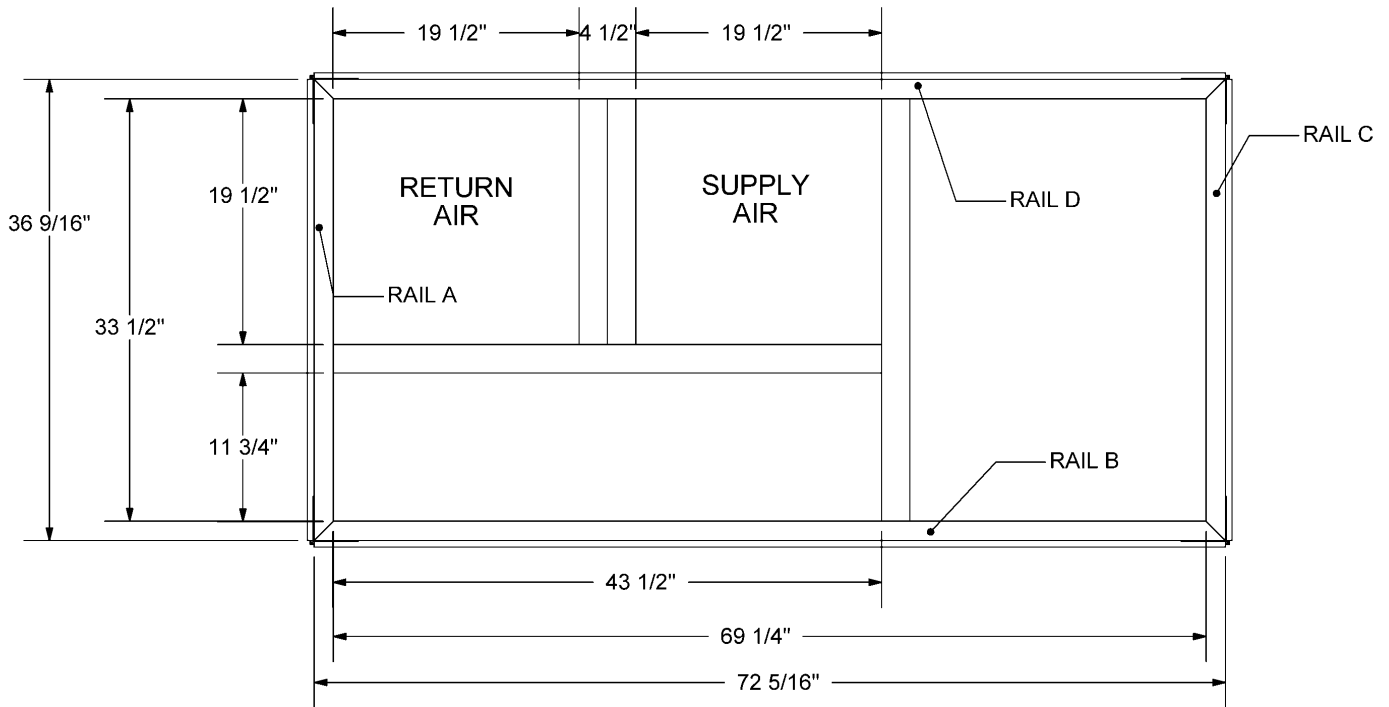

## FEATURES

- SHIPPED ASSEMBLED OR KNOCK DOWN
- MITERED TOP CORNERS
- FABRICATED OF ALUMINUM EXTRUSION
- FULL PERIMETER WEATHER SEAL
- 1" OR 2" STATIC DEFLECTION
- DUCT SUPPORTS INCLUDED
- ROOF CURB SOLD SEPARATELY
- CANVAS DUCT CONNECTIONS (NOT INCLUDED)

