

DATE: \_\_\_\_\_  
 COMPANY: \_\_\_\_\_  
 JOB NAME: \_\_\_\_\_  
 SUBMITTED BY: \_\_\_\_\_  
 NOTES: \_\_\_\_\_  
 \_\_\_\_\_

FLUSH MOUNT FLEX DUCT CONCENTRIC KIT  
 SUBMITTAL DATA FOR:

**TRANE UNITS**  
**TCD/WCD/YCD210-240B**  
**TCD/YCD211-241B**

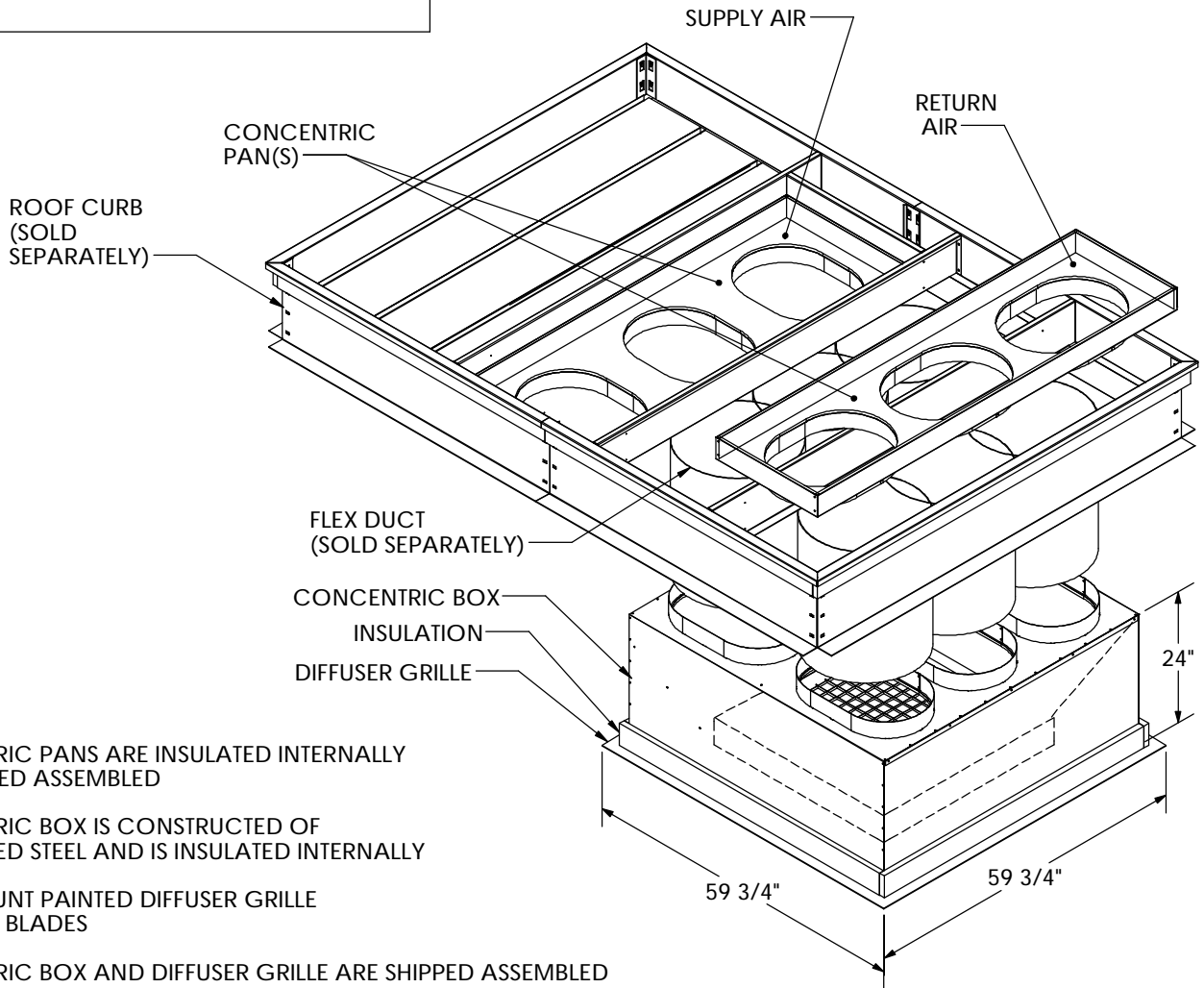

**FEATURES:**

CONCENTRIC PANS ARE INSULATED INTERNALLY AND SHIPPED ASSEMBLED

CONCENTRIC BOX IS CONSTRUCTED OF GALVANIZED STEEL AND IS INSULATED INTERNALLY

FLUSH MOUNT PAINTED DIFFUSER GRILLE WITH FIXED BLADES

CONCENTRIC BOX AND DIFFUSER GRILLE ARE SHIPPED ASSEMBLED

CAMBRIDGEPORT PART NUMBER	DUCT SIZE	APPLICABLE CURB MODEL NUMBERS	FLEX (SOLD SEPARATELY)	NOMINAL CFM	THROW IN FT.	
					MIN	MAX
1012444	6 @ 20"	BAYCURB027	1000090 (2-20") (3 REQUIRED)	7,000-8,000	28	50

**NOTES:**

- 1 - INSTALL INSULATED ADAPTER PANS BEFORE A/C UNIT IS PLACED ON CURB.
- 2 - FIELD BAFFLES MAY BE REQUIRED FOR BALANCING
- 3 - CONCENTRIC BOX MUST BE FIELD SUPPORTED

Drawn By: CRF  
 Date: 1/23/08 Rev: 0

**Cambridgeport**

**AIR SYSTEMS**

MEMPHIS, TN 38118

PHONE 1-877-648-2872 FAX 901-566-0035

SALISBURY, MA 01952

PHONE 1-800-648-2872 FAX 978-462-9189