

DATE: _____
 COMPANY: _____
 JOB NAME: _____
 SUBMITTED BY: _____
 NOTES: _____

SUBMITTAL

CARRIER CPRFCURB013A00

ROOF CURB

1014902

DRAWN BY: RTO

DRAWN DATE: 9/22/2009

EST. WEIGHT: 90.01

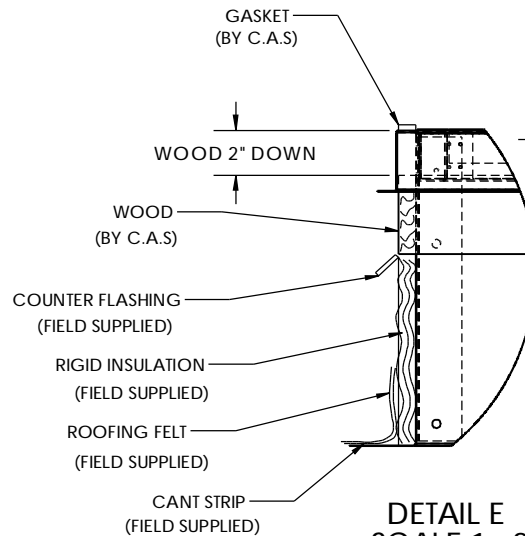
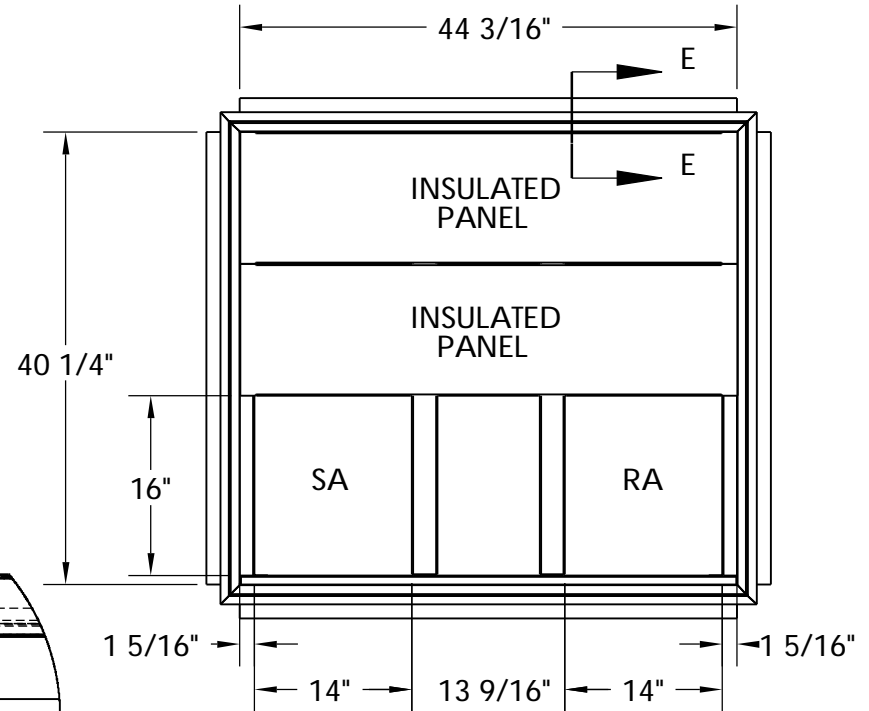
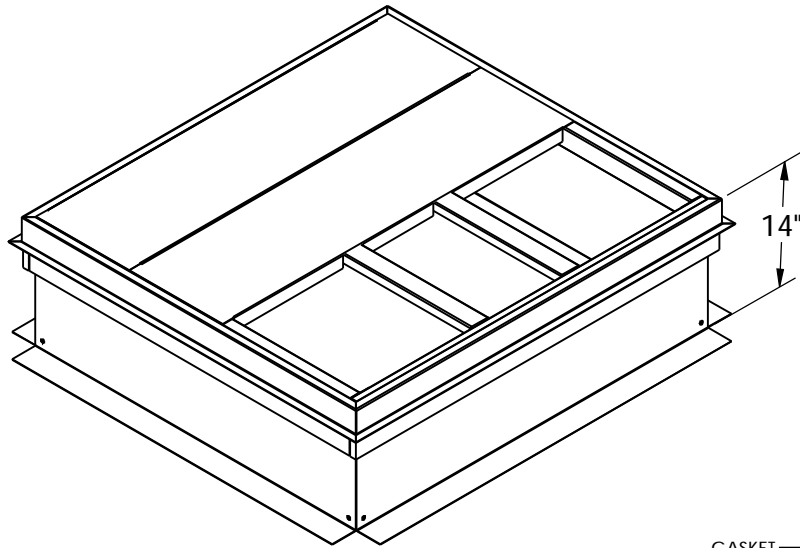

DETAIL E
 SCALE 1 : 8

FEATURES:

MITERED TOP CORNERS

ROOF CURB MADE OF HEAVY GAUGE GALVANIZED STEEL.

PREPUNCHED ASSEMBLY HOLES AND HARDWARE INCLUDED FOR DUCT SUPPORT INSTALLATION.

FULL PERIMETER WOOD NAILER.

GASKETING PROVIDED FOR UNIT TO CURB SEALING.

ROOF CURB IS SHIPPED UNASSEMBLED.

Cambridgeport

HVAC Accessories & Engineered Systems

SALISBURY, MA 01952

PHONE 1-800-648-2872 FAX 1-9780462-9189